

THE MAN TGE **NEXT LEVEL.**

UK Retail Price List & Technical Data.
Valid from 1 January 2025.







Model Year 2025.









CONTENTS

MAN TGE Overview	4
Panel Van	5
Single Cab Chassis	11
Flatframe Cowl	14
Crew Cab Chassis	15
Standard Specification	18
Driveline	20
Fuel Consumption & Emissions	21
Dimensions	27
Weights	33
Manufacturer's Options	37
Tyre Labels	44
Notes	46

MAN TGE OVERVIEW.

	Panel van		
	Standard	Long	Extra-long
	Length: 5,986 mm Wheelbase: 3,640 mm	Length: 6,836 mm Wheelbase: 4,490 mm	Length: 7,391 mm Wheelbase: 4,490 mm
Normal roof Height: 2,355 mm / 2,390 mm ¹			
High roof Height: 2,590 mm / 2,625 mm ¹			
Super-high roof Height: 2,798 mm / 2,835 mm ¹			

	Cowl Flatframe	
	Standard	Long
	Length: 5,797 mm Wheelbase: 3,640 mm	Length: 6,648 mm Wheelbase: 4,490 mm
Cowl Flatframe Height: 2,305 mm ³		

	Chassis		
	Standard	Long	Extra-long
	Length: 5,996/ 5,968 ² mm Wheelbase: 3,640 mm	Length: 6,846/ 6,818 ² mm Wheelbase: 4,490 mm	Length: 7,211 mm Wheelbase: 4,490 mm
Chassis cab Height: 2,305 mm ³ / 2,339 mm ¹			
Crew cab Height: 2,321 mm ³ / 2,339 mm ¹			

Weight variants: 3.5 t, 3.88 t, 4.0 t, 5.0 t, 5.5 t plus towed loads of 2.0 to 3.5 t.

Engine variants: 2.0 l turbo diesel: 103 kW (light duty), 2.0 l BiTurbo diesel: 103 kW (heavy duty), 120 kW (heavy duty), 130 kW (light duty).

¹ For twin-tyre configuration (if more wheel bases are shown the value is valid for wheelbase "long").

² Value valid for twin-tyre configuration.

³ For wheel base "long".

MAN TGE PANEL VAN.

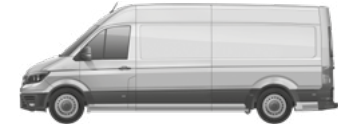

MAN TGE Panel Van with Front Wheel Drive

Model	Gross Weight [t]	Engine Power [kW (PS)]	Transmission	Length	Wheelbase [mm]	Load Space L x W [mm]	Roof Height	Load Space Height [mm]	Load Volume [m³]	LION XS RRP [£]	LION XC RRP [£]	LION XP RRP [£]
3.140	3.5	103 (140) (LD & HD)	6 Speed Manual	Standard	3,640	3,450 x 1,832	Normal	1,726	9.9	£39,697	£41,968	£44,788
				High	1,961	11.3	£40,906	£43,177	£45,997			
				High	1,961	14.4	£42,743	£45,089	£47,918			
				Super High	2,189	16.1	£45,114	£47,469	£50,289			
				High	1,961	16.4	£43,751	£46,190	£49,010			
				Super High	2,196	18.4	£46,176	£48,651	£51,435			
			8 Speed Automatic	Standard	3,640	3,450 x 1,832	Normal	1,726	9.9	£42,525	£44,796	£47,616
				High	1,961	11.3	£43,734	£46,005	£48,825			
				High	1,961	14.4	£45,569	£47,924	£50,744			
				Super High	2,189	16.1	£47,940	£50,295	£53,115			
				High	1,961	16.4	£46,577	£49,016	£51,836			
				Super High	2,196	18.4	£49,002	£51,441	£54,261			
3.160	3.5	120 (163) (HD)	6 Speed Manual	Standard	3,640	3,450 x 1,832	Normal	1,726	9.9	£41,070	£43,341	£46,161
				High	1,961	11.3	£42,279	£44,550	£47,370			
				High	1,961	14.4	£44,117	£46,472	£49,292			
				Super High	2,189	16.1	£46,488	£48,843	£51,663			
				High	1,961	16.4	£45,123	£47,560	£50,382			
				Super High	2,196	18.4	£47,548	£49,987	£52,807			
			8 Speed Automatic	Standard	3,640	3,450 x 1,832	Normal	1,726	9.9	£43,898	£46,169	£48,989
				High	1,961	11.3	£45,107	£47,378	£50,198			
				High	1,961	14.4	£46,943	£49,298	£52,118			
				Super High	2,189	16.1	£49,314	£51,669	£54,489			
				High	1,961	16.4	£47,949	£50,388	£53,208			
				Super High	2,196	18.4	£50,374	£52,813	£55,633			

Notes:

1. VAT, Road Fund Licence and DVLA First Registration Fee extra at applicable rates.

2. An additional £1050 plus VAT (net) is chargeable on all transactions for standard manufacturer's delivery charge and incidentals.

MAN TGE PANEL VAN.

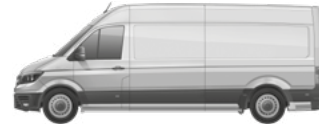

MAN TGE Panel Van with Front Wheel Drive

Model	Gross Weight [t]	Engine Power [kW (PS)]	Transmission	Length	Wheelbase [mm]	Load Space LxW [mm]	Roof Height	Load Space Height [mm]	Load Volume [m³]	LION XS RRP [£]	LION XC RRP [£]	LION XP RRP [£]
3.180	3.5	130 (177) (LD)	6 Speed Manual	Standard	3,640	3,450 x 1,832	Normal	1,726	9.9	£41,877	£44,148	£46,968
							High	1,961	11.3	£43,086	£45,357	£48,177
				Long	4,490	4,300 x 1,832	High	1,961	14.4	£44,923	£47,274	£50,098
							Super High	2,189	16.1	£47,294	£49,649	£52,468
				Extra Long	4,490	4,855 x 1,832	High	1,961	16.4	£45,929	£48,368	£51,188
							Super High	2,196	18.4	£48,354	£50,793	£53,613
			8 Speed Automatic	Standard	3,640	3,450 x 1,832	Normal	1,726	9.9	£44,703	£46,974	£49,794
							High	1,961	11.3	£45,912	£48,183	£51,003
				Long	4,490	4,300 x 1,832	High	1,961	14.4	£47,748	£50,103	£52,923
							Super High	2,189	16.1	£50,119	£52,474	£55,294
				Extra Long	4,490	4,855 x 1,832	High	1,961	16.4	£48,755	£51,194	£53,014
							Super High	2,196	18.4	£51,180	£53,619	£56,439

Notes:

1. VAT, Road Fund Licence and DVLA First Registration Fee extra at applicable rates.
2. An additional £1050 plus VAT (net) is chargeable on all transactions for standard manufacturer's delivery charge and incidentals.

MAN TGE PANEL VAN.



MAN TGE Panel Van with All Wheel Drive

Model	Gross Weight [t]	Engine Power [kW (PS)]	Transmission	Length	Wheelbase [mm]	Load Space LxW [mm]	Roof Height	Load Space Height [mm]	Load Volume [m³]	LION XS RRP [£]	LION XC RRP [£]	LION XP RRP [£]				
3.160 4x4	3.5	120 (163) (HD)	8 Speed Automatic	Standard	3,640	3,450 x 1,832	Normal	1,626	9.3	£48,090	£50,361	£53,181				
							High	1,861	10.7	£49,299	£51,570	£54,390				
				Long	4,490	4,300 x 1,832	High	1,861	13.6	£51,135	£53,490	£56,310				
							Super High	2,089	15.3	£53,506	£55,861	£58,681				
				Extra Long	4,490	4,855 x 1,832	High	1,861	15.5	£52,143	£54,582	£57,402				
							Super High	2,089	17.5	£54,568	£57,007	£59,827				
				3.180 4x4	3.5	130 (177) (LD)	8 Speed Automatic	Standard	3,640	3,450 x 1,832	Normal	1,626	9.3	£48,896	£41,167	£53,987
											High	1,861	10.7	£50,105	£52,376	£55,196
								Long	4,490	4,300 x 1,832	High	1,861	13.6	£51,941	£54,269	£57,116
											Super High	2,089	15.3	£54,312	£56,667	£59,487
								Extra Long	4,490	4,855 x 1,832	High	1,861	15.5	£52,949	£55,388	£58,208
											Super High	2,089	17.5	£55,347	£57,813	£60,633

Notes:

1. VAT, Road Fund Licence and DVLA First Registration Fee extra at applicable rates.
2. An additional £1050 plus VAT (net) is chargeable on all transactions for standard manufacturer's delivery charge and incidentals.

MAN TGE PANEL VAN.



MAN TGE Panel Van with Rear Wheel Drive

Model	Gross Weight [t]	Engine Power [kW (PS)]	Transmission	Length	Wheelbase [mm]	Load Space LxW [mm]	Roof Height	Load Space Height [mm]	Load Volume [m³]	LION XS RRP [£]	LION XC RRP [£]	LION XP RRP [£]
3.160	3.5	120 (163) (HD)	6 Speed Manual	Standard	3,640	3,450 x 1,832	Normal	1,626	9.3	£41,659	£43,930	£46,750
				High	1,861	10.7	£42,868	£45,139	£47,959			
				Long	4,490	4,300 x 1,832	High	1,861	13.6	£44,704	£47,059	£49,879
			8 Speed Automatic	Standard	3,640	3,450 x 1,832	Normal	1,626	9.3	£44,486	£46,757	£49,577
				High	1,861	10.7	£45,659	£47,966	£50,786			
				Long	4,490	4,300 x 1,832	High	1,861	13.6	£47,532	£49,887	£52,707
5.160	5.0	120 (163) (HD)	6 Speed Manual	Standard	3,640	3,450 x 1,832	Normal	1,626	9.3	£45,983	£48,254	£51,074
				High	1,861	10.7	£47,192	£49,463	£52,283			
				High	1,861	13.6	£49,595	£51,950	£54,770			
				Super High	2,089	15.3	£51,966	£54,321	£57,141			
				High	1,861	15.5	£50,604	£53,043	£55,863			
				Super High	2,089	17.5	£53,029	£55,468	£58,288			
			8 Speed Automatic	Standard	3,640	3,450 x 1,832	Normal	1,626	9.3	£48,810	£51,081	£53,901
				High	1,861	10.7	£50,019	£52,290	£55,110			
				High	1,861	13.6	£52,422	£54,777	£57,597			
				Super High	2,089	15.3	£54,793	£57,148	£59,968			
				High	1,861	15.5	£53,431	£55,870	£58,690			
				Super High	2,089	17.5	£55,856	£58,259	£61,115			

Notes:

1. VAT, Road Fund Licence and DVLA First Registration Fee extra at applicable rates.
2. An additional £1050 plus VAT (net) is chargeable on all transactions for standard manufacturer's delivery charge and incidentals.

MAN TGE PANEL VAN.

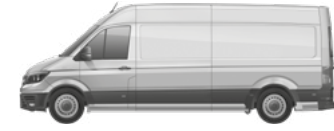

MAN TGE Panel Van with Rear Wheel Drive

Model	Gross Weight [t]	Engine Power [kW (PS)]	Transmission	Length	Wheelbase [mm]	Load Space LxW [mm]	Roof Height	Load Space Height [mm]	Load Volume [m³]	LION XS RRP [£]	LION XC RRP [£]	LION XP RRP [£]
3.160	3.5	120 (163) (HD)	6 Speed Manual	Standard	3,640	3,450 x 1,832	Normal	1,626	9.3	£49,241	£51,512	£54,332
				High	1,861	10.7	£50,450	£52,721	£55,541			
				Long	4,490	4,300 x 1,832	High	1,861	13.6	£52,853	£55,208	£58,028
			8 Speed Automatic	Standard	3,640	3,450 x 1,832	Normal	1,626	9.3	£49,241	£51,512	£54,332
				High	1,861	10.7	£50,450	£52,721	£55,541			
				Long	4,490	4,300 x 1,832	High	1,861	13.6	£52,853	£55,208	£58,028
6.160	5.5	120 (163) (HD)	6 Speed Manual	Standard	3,640	3,450 x 1,832	Normal	1,626	9.3	£49,241	£51,512	£54,332
				High	1,861	10.7	£50,450	£52,721	£55,541			
				High	1,861	13.6	£52,853	£55,208	£58,028			
				Super High	2,089	15.3	£55,224	£57,579	£60,399			
				High	1,861	15.5	£53,861	£56,300	£59,120			
				Super High	2,089	17.5	£56,286	£58,725	£61,545			
			8 Speed Automatic	Standard	3,640	3,450 x 1,832	Normal	1,626	9.3	£52,065	£54,336	£57,156
				High	1,861	10.7	£53,274	£55,545	£58,365			
				High	1,861	13.6	£55,681	£58,036	£60,856			
				Super High	2,089	15.3	£58,052	£60,407	£63,227			
				High	1,861	15.5	£56,688	£59,127	£61,947			
				Super High	2,089	17.5	£59,113	£61,552	£64,372			

Notes:

1. VAT, Road Fund Licence and DVLA First Registration Fee extra at applicable rates.
2. An additional £1050 plus VAT (net) is chargeable on all transactions for standard manufacturer's delivery charge and incidentals.

MAN TGE PANEL VAN.



MAN TGE Panel Van with Rear Wheel Drive (Super-Single Rear Tyres)

Model	Gross Weight [t]	Engine Power [kW (PS)]	Transmission	Length	Wheelbase [mm]	Load Space L x W [mm]	Roof Height	Load Space Height [mm]	Load Volume [m³]	LION XS RRP [£]
5.160	4.8*	120 (163) (HD)	6 Speed Manual	Standard	3,640	3,450 x 1,832	Normal	1,626	9.3	£46,931
							High	1,861	10.7	£48,140
				Long	4,490	4,300 x 1,832	High	1,861	13.6	£50,544
							Super High	2,089	15.3	£52,915
							High	1,861	15.5	£51,551
							Super High	2,096	17.5	£53,976
			8 Speed Automatic	Standard	3,640	3,450 x 1,832	Normal	1,626	9.3	£49,757
							High	1,861	10.7	£50,966
				Long	4,490	4,300 x 1,832	High	1,861	13.6	£53,371
							Super High	2,089	15.3	£55,742
							High	1,861	15.5	£54,378
							Super High	2,096	17.5	£56,803

Notes:

- VAT, Road Fund Licence and DVLA First Registration Fee extra at applicable rates.
 - An additional £1050 plus VAT (net) is chargeable on all transactions for standard manufacturer's delivery charge and incidentals.
- *Maximum value subject to vehicle length

MAN TGE CHASSIS.



TGE Single Cab Chassis with Front Wheel Drive

Model	Gross Weight [t]	Engine Power [kW (PS)]	Transmission	Length	Wheelbase [mm]	RRP [£]
3.140	3.5	103 (140) (LD & HD)	6 Speed Manual	Standard	3,640	£37,198
				Long	4,490	£39,118
			8 Speed Automatic	Standard	3,640	£40,024
				Long	4,490	£41,943
3.160	3.5	120 (163) (HD)	6 Speed Manual	Standard	3,640	£38,572
				Long	4,490	£40,489
			8 Speed Automatic	Standard	3,640	£41,399
				Long	4,490	£43,317
3.180	3.5	130 (177) (LD)	6 Speed Manual	Standard	3,640	£39,377
				Long	4,490	£41,296
			8 Speed Automatic	Standard	3,640	£42,204
				Long	4,490	£44,124

Notes:

- VAT, Road Fund Licence and DVLA First Registration Fee extra at applicable rates.
- An additional £1050 plus VAT (net) is chargeable on all transactions for standard manufacturer's delivery charge and incidentals.

MAN TGE CHASSIS.



TGE Single Cab Chassis with All Wheel Drive

Model	Gross Weight [t]	Engine Power [kW (PS)]	Transmission	Length	Wheelbase [mm]	RRP [£]
3.160 4X4	3.5	120 (163) (HD)	8 Speed Automatic	Standard	3,640	£45,590
				Long	4,490	£47,508
3.180 4X4	3.5	130 (177) (LD)	8 Speed Automatic	Standard	3,640	£46,397
				Long	4,490	£48,315

Notes:

1. VAT, Road Fund Licence and DVLA First Registration Fee extra at applicable rates.
2. An additional £1050 plus VAT (net) is chargeable on all transactions for standard manufacturer's delivery charge and incidentals.

MAN TGE CHASSIS.



TGE Single Cab Chassis with Rear Wheel Drive

Model	Gross Weight [t]	Engine Power [kW (PS)]	Transmission	Length	Wheelbase [mm]	RRP [£]
3.160	3.5	120 (163) (HD)	6 Speed Manual	Standard	3,640	£39,160
				Long	4,490	£41,078
			8 Speed Automatic	Standard	3,640	£41,986
				Long	4,490	£43,904
			6 Speed Manual	Standard	3,640	£43,601
				Long	4,490	£45,520
5.160	5.0	120 (163) (HD)	8 Speed Automatic	Standard	3,640	£46,528
				Long	4,490	£46,427
			8 Speed Automatic	Long	4,490	£48,347
				Extra Long	4,490	£49,355
			6 Speed Manual	Standard	3,640	£46,859
				Long	4,490	£48,779
6.160	5.5	120 (163) (HD)	6 Speed Manual	Extra Long	4,490	£49,785
				Standard	3,640	£49,685
			8 Speed Automatic	Long	4,490	£51,604
				Extra Long	4,490	£52,612

Notes:

1. VAT, Road Fund Licence and DVLA First Registration Fee extra at applicable rates.
2. An additional £1050 plus VAT (net) is chargeable on all transactions for standard manufacturer's delivery charge and incidentals.

MAN TGE CHASSIS.



TGE Flatframe Cowl with Front Wheel Drive

Model	Gross Weight [t]	Engine Power [kW (PS)]	Transmission	Length	Wheelbase [mm]	RRP [£]
3.140	3.5	103 (140) (HD)	6 Speed Manual	Standard	3,640	£37,379
				Long	4,490	£39,297
			8 Speed Automatic	Standard	3,640	£40,205
				Long	4,490	£42,124
3.160	3.5	120 (163) (HD)	6 Speed Manual	Standard	3,640	£38,751
				Long	4,490	£40,672
			8 Speed Automatic	Standard	3,640	£41,578
				Long	4,490	£43,497

Notes:

1. VAT, Road Fund Licence and DVLA First Registration Fee extra at applicable rates.
2. An additional £1050 plus VAT (net) is chargeable on all transactions for standard manufacturer's delivery charge and incidentals.

MAN TGE CHASSIS.



TGE Crew Cab Chassis with Front Wheel Drive

Model	Gross Weight [t]	Engine Power [kW (PS)]	Transmission	Length	Wheelbase [mm]	RRP [£]
3.140	3.5	103 (140) (LD & HD)	6 Speed Manual	Standard	3,640	£39,805
				Long	4,490	£41,723
			8 Speed Automatic	Standard	3,640	£42,629
				Long	4,490	£44,549
3.160	3.5	120 (163) (HD)	6 Speed Manual	Standard	3,640	£41,178
				Long	4,490	£43,096
			8 Speed Automatic	Standard	3,640	£44,003
				Long	4,490	£45,921
3.180	3.5	130 (177) (LD)	6 Speed Manual	Standard	3,640	£41,984
				Long	4,490	£43,902
			8 Speed Automatic	Standard	3,640	£44,810
				Long	4,490	£46,727

Notes:

1. VAT, Road Fund Licence and DVLA First Registration Fee extra at applicable rates.
2. An additional £1050 plus VAT (net) is chargeable on all transactions for standard manufacturer's delivery charge and incidentals.

MAN TGE CHASSIS.



TGE Crew Cab Chassis with All Wheel Drive

Model	Gross Weight [t]	Engine Power [kW (PS)]	Transmission	Length	Wheelbase [mm]	RRP [£]
3.160 4x4	3.5	120 (163) (HD)	8 Speed Automatic	Standard	3,640	£48,197
				Long	4,490	£50,115
3.180 4x4	3.5	130 (177) (LD)	8 Speed Automatic	Standard	3,640	£49,003
				Long	4,490	£50,992

Notes:

1. VAT, Road Fund Licence and DVLA First Registration Fee extra at applicable rates.
2. An additional £1050 plus VAT (net) is chargeable on all transactions for standard manufacturer's delivery charge and incidentals.

MAN TGE CHASSIS.



TGE Crew Cab Chassis with Rear Wheel Drive

Model	Gross Weight [t]	Engine Power [kW (PS)]	Transmission	Length	Wheelbase [mm]	RRP [£]
3.160	3.5	120 (163) (HD)	6 Speed Manual	Standard	3,640	£41,767
				Long	4,490	£43,685
			8 Speed Automatic	Standard	3,640	£44,593
				Long	4,490	£46,511
5.160	5.0	120 (163) (HD)	6 Speed Manual	Standard	3,640	£46,138
				Long	4,490	£48,056
			8 Speed Automatic	Standard	3,640	£48,964
				Long	4,490	£50,882
6.160	5.5	120 (163) (HD)	6 Speed Manual	Long	4,490	£51,312
			8 Speed Automatic	Long	4,490	£54,139

Notes:

1. VAT, Road Fund Licence and DVLA First Registration Fee extra at applicable rates.
2. An additional £1050 plus VAT (net) is chargeable on all transactions for standard manufacturer's delivery charge and incidentals.

SPECIFICATION.

MAN TGE - LION XS Panel Van & Chassis Models Standard Specification

Audio and Communications	Exterior
MAN Media Van 10.4" colour touchscreen, USB and Bluetooth connection, 4 speakers	Manually adjustable door mirrors
DAB+	Rear wing doors with 270° hinges (Panel van only)
Smartphone integration	Manual side sliding door passenger side (Panel van only)
3-button-module for information and emergency calls*	High roof (Panel van only)
USB-C Sockets	75 litre fuel tank
Wireless phone charging	30 litre AdBlue® tank
Cab	Safety and Security
Multi-function steering wheel	Anti-lock Braking System (ABS)
MAN fabric seat covers	Electronic Brake Assist (EBA)
Digital instrumentation	Start-stop system with regenerative braking
Electronic parking brake	Electronic Stability Control (ESC)
Keyless go	Cross Wind Assist
Comfort single driver's seat including 2-way lumbar support, armrest and height adjustment	Driver and passenger airbag
Dual passenger seat	Engine immobiliser
Electromechanical steering	Remote central locking with two remote keys
Rubber floor covering	Seatbelt warning light for driver and passenger
Steering wheel with reach and rake adjustment	Windscreen wiper with variable intermittent delay and wash-wipe system
12v socket	Hill start assist
Overhead storage compartment with two 1-DIN standard slots*	Cruise control
	Event data recorder
	Dynamic road sign display
	Park distance control in front and rear
	Active lane keeping system
	Driver alert system
	Tyre pressure monitoring system
	Preparation for alcohol ignition interlock
Cargo Area (Panel van only)	
Full-height steel bulkhead without window	
Rear wing doors without window	
Two load-lashing rings on 'B' pillar	
Grab handles on rear entry pillars	
Lashing rings for load restraint system	

*Not cowl models

Electrics
Alternator 180 A
Battery 520 A (92 Ah)
Preparation for Bodybuilder module
Halogen main headlights with range control and daytime running function
Operating voltage 12 V
Wheels and Tyres
16" x 6.5J steel wheels
Full size steel spare wheel
Tool kit and jack
Tyres with low rolling resistance

SPECIFICATION.

MAN TGE - LION XC Panel Van Standard Specification (in addition to LION XS)

Cab
Climatic air conditioning
Cargo Area
Cargo area anti-slip floor covering
Exterior
Electrically heated and adjustable mirrors

MAN TGE - LION XP Panel Van Standard Specification (in addition to LION XS)

Audio and Communications
MAN Media Van Navigation, 10.4" colour touchscreen, 4 speakers
Rear view camera
Cab
Dual passenger seat with additional storage
Climatronic air conditioning
Cargo Area
Cargo area anti-slip floor covering
Safety and Security
Blind spot warning
Lane change system
Exterior
Electrically heated, foldable and adjustable mirrors
Wheel caps with chrome emblem

DRIVELINE.

Diesel engines	2.0 litres 103 kW	2.0 litres 120 kW	2.0 litres 130 kW
Engine size [cm³]	1,968	1,968	1,968
Number of cylinders	4	4	4
Max. power [kW (HP)]	103 (140)	120 (163)	130 (177)
at rpm [1/min]	3,500-3,600* / 3,600**	3,600	3,600
Max. torque [Nm]	360	410	410
at rpm [1/min]	1,500-2,500	1,500–2,000	1,500–2,000
Emissions	EU6e (EA)* / EuroVle**	EuroVle**	EU6e (EA)*
Fuel type	Diesel, as per DIN EN 590	Diesel, as per DIN EN 590	Diesel, as per DIN EN 590
Transmission	6-gear manual transmission ¹ 8-gear automatic transmission	6-gear manual transmission ¹ 8-gear automatic transmission	6-gear manual transmission ¹ 8-gear automatic transmission
Drive	Front-wheel drive	Front-wheel drive All-wheel drive Rear-wheel drive with single-tyre configuration Rear-wheel drive with twin-tyre configuration	Front-wheel drive All-wheel drive

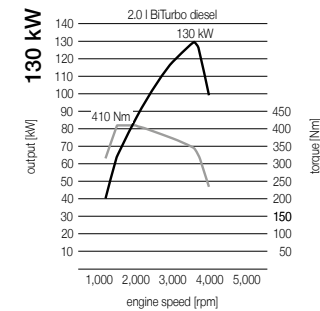
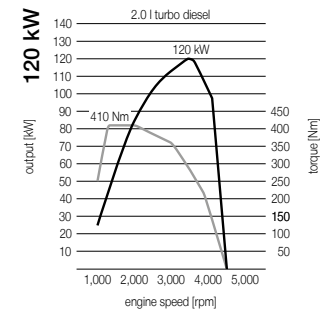
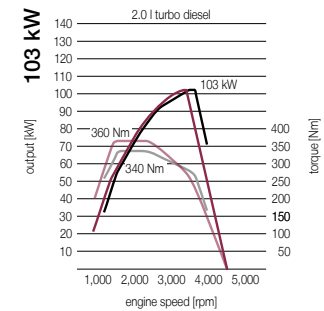

— * for light duty. — ** for heavy duty.

Noise emissions: Not available at time of printing.

Notes:

* Light duty homologation.

** Heavy duty homologation.

¹ Not for all-wheel drive.

FUEL CONSUMPTION & EMISSIONS.

MAN TGE Panel Van with High Roof - LION XS

Gross Weight [t]	Engine Power [kW (PS)]	Drive Type	Transmission	Length	Consumption (low)		Consumption (medium)		Consumption (high)		Consumption (extra-high)		Consumption (combined)		CO2 (combined) g/km
					1/100km	MPG	1/100km	MPG	1/100km	MPG	1/100km	MPG	1/100km	MPG	
3.140	103 (140)	Front	Manual	Standard	8.9	31.7	7.9	35.8	7.5	37.7	10.0	28.3	8.7	32.5	228
				Long	9.1	31.0	8.0	35.3	7.6	37.2	10.1	28.0	8.8	32.1	230
				Extra Long	9.1	31.0	8.1	34.9	7.6	37.2	10.1	28.0	8.8	32.1	232
			Automatic	Standard	10.4	27.2	8.6	32.8	8.0	35.3	10.7	26.4	9.4	30.1	247
				Long	10.6	26.7	8.7	32.5	8.1	34.9	10.8	26.2	9.5	29.7	249
				Extra Long	10.7	26.4	8.8	32.1	8.2	34.5	10.9	25.9	9.6	29.4	252
3.160	120 (163)	Front	Manual	Standard	13.1	21.6	11.4	24.8	11.6	24.4	16.3	17.3	13.4	21.1	351
				Long	13.1	21.6	11.4	24.8	11.6	24.4	16.3	17.3	13.4	21.1	351
				Extra Long	13.1	21.6	11.4	24.8	11.6	24.4	16.3	17.3	13.4	21.1	351
			Automatic	Standard	13.1	21.6	11.4	24.8	11.6	24.4	16.3	17.3	13.4	21.1	351
				Long	13.1	21.6	11.4	24.8	11.6	24.4	16.3	17.3	13.4	21.1	351
				Extra Long	13.1	21.6	11.4	24.8	11.6	24.4	16.3	17.3	13.4	21.1	351
3.180	130 (177)	Front	Manual	Standard	10.2	27.7	8.3	34.0	7.8	36.2	10.5	26.9	9.2	30.7	241
				Long	10.3	27.4	8.4	33.6	7.9	35.8	10.6	26.7	9.3	30.4	244
				Extra Long	10.4	27.2	8.5	33.2	7.9	35.8	10.6	26.7	9.3	30.4	245
			Automatic	Standard	10.9	25.9	8.7	32.5	8.1	34.9	10.8	26.2	9.5	29.7	250
				Long	11.1	25.5	8.8	32.1	8.2	34.5	10.9	25.9	9.6	29.4	252
				Extra Long	11.2	25.2	8.9	31.7	8.2	34.5	10.9	25.9	9.7	29.1	255
3.160	120 (163)	4x4	Automatic	Standard	13.1	21.6	11.4	24.8	11.6	24.4	16.3	17.3	13.4	21.1	351
				Long	13.1	21.6	11.4	24.8	11.6	24.4	16.3	17.3	13.4	21.1	351
				Extra Long	13.1	21.6	11.4	24.8	11.6	24.4	16.3	17.3	13.4	21.1	351
			Automatic	Standard	12.2	23.2	9.5	29.7	8.7	32.5	11.0	25.7	10.1	28.0	266
				Long	12.3	23.0	9.7	29.1	8.8	32.1	11.1	25.5	10.2	27.7	269
				Extra Long	12.4	22.8	9.8	28.8	8.8	32.1	11.2	25.2	10.3	27.4	272

All values shown on this page are in accordance WLTP testing regimes. Actual performance will depend on driving style, road conditions, chosen optional extras and other non-technical factors.

Values shown are for standard specification only; changes to base specification will alter these values.

Contact your MAN Sales Specialist for exact values for your specification.

*Vehicle not subject to WLTP testing regime / data not yet available

FUEL CONSUMPTION & EMISSIONS.

Gross Weight [t]	Engine Power [kW (PS)]	Drive Type	Transmission	Length	Consumption (low)		Consumption (medium)		Consumption (high)		Consumption (extra-high)		Consumption (combined)		CO2 (combined) g/km	
					1/100km	MPG	1/100km	MPG	1/100km	MPG	1/100km	MPG	1/100km	MPG		
3.160	120 (163)	Rear	Manual	Standard	13.0	21.7	11.3	25.0	11.4	24.8	15.2	18.6	12.9	21.9	339	
				Long	11.4	24.8	9.3	30.4	8.9	31.7	12.0	23.5	10.4	27.2	273	
				Extra Long	13.1	21.6	11.4	24.8	11.6	24.4	16.3	17.3	13.4	21.1	351	
			Automatic	Standard	*	*	*	*	*	*	*	*	*	*	*	*
				Long	*	*	*	*	*	*	*	*	*	*	*	*
				Extra Long	13.1	21.6	11.4	24.8	11.6	24.4	16.3	17.3	13.4	21.1	351	
5.160	120 (163)	Rear	Manual	Standard	11.8	23.9	9.7	29.1	10.1	28.0	14.9	19.0	11.9	23.7	313	
				Long	11.8	23.9	9.7	29.1	10.1	28.0	14.9	19.0	11.9	23.7	313	
				Extra Long	*	*	*	*	*	*	*	*	*	*	*	
			Automatic	Standard	*	*	*	*	*	*	*	*	*	*	*	*
				Long	*	*	*	*	*	*	*	*	*	*	*	*
				Extra Long	*	*	*	*	*	*	*	*	*	*	*	*
6.160	120 (177)	Rear	Manual	Standard	*	*	*	*	*	*	*	*	*	*		
				Long	*	*	*	*	*	*	*	*	*	*		
				Extra Long	*	*	*	*	*	*	*	*	*	*		
			Automatic	Standard	*	*	*	*	*	*	*	*	*	*	*	
				Long	*	*	*	*	*	*	*	*	*	*	*	
				Extra Long	*	*	*	*	*	*	*	*	*	*	*	

All values shown on this page are in accordance WLTP testing regimes. Actual performance will depend on driving style, road conditions, chosen optional extras and other non-technical factors. Values shown are for standard specification only; changes to base specification will alter these values. Contact your MAN Sales Specialist for exact values for your specification. *Vehicle not subject to WLTP testing regime / data not yet available

FUEL CONSUMPTION & EMISSIONS.

MAN TGE Panel Van with High Roof - LION XC

Gross Weight [t]	Engine Power [kW (PS)]	Drive Type	Transmission	Length	Consumption (low)		Consumption (medium)		Consumption (high)		Consumption (extra-high)		Consumption (combined)		CO2 (combined) g/km
					1/100km	MPG	1/100km	MPG	1/100km	MPG	1/100km	MPG	1/100km	MPG	
3.140	103 (140)	Front	Manual	Standard	9.0	31.4	8.0	35.3	7.6	37.2	10.1	28.0	8.7	32.5	229
				Long	9.0	31.4	8.2	34.5	7.6	37.2	10.2	27.7	8.8	32.1	232
				Extra Long	9.3	31.4	8.2	34.5	7.7	36.7	10.2	27.7	8.9	31.7	234
			Automatic	Standard	10.5	26.9	8.7	32.5	8.1	34.9	10.8	26.2	9.5	29.7	249
				Long	10.7	26.4	8.8	32.1	8.2	34.5	10.9	25.9	9.6	29.4	252
				Extra Long	10.8	26.2	9.0	31.4	8.2	34.5	11.0	25.7	9.7	29.1	254
3.160	120 (163)	Front	Manual	Standard	13.1	21.6	11.4	24.8	11.6	24.4	16.3	17.3	13.4	21.1	351
				Long	13.1	21.6	11.4	24.8	11.6	24.4	16.3	17.3	13.4	21.1	351
				Extra Long	13.1	21.6	11.4	24.8	11.6	24.4	16.3	17.3	13.4	21.1	351
			Automatic	Standard	13.1	21.6	11.4	24.8	11.6	24.4	16.3	17.3	13.4	21.1	351
				Long	13.1	21.6	11.4	24.8	11.6	24.4	16.3	17.3	13.4	21.1	351
				Extra Long	13.1	21.6	11.4	24.8	11.6	24.4	16.3	17.3	13.4	21.1	351
3.180	130 (177)	Front	Manual	Standard	10.3	27.4	8.4	33.6	7.9	35.8	10.6	26.7	9.3	30.4	243
				Long	10.4	27.2	8.5	33.2	8.0	35.3	10.6	26.7	9.4	30.1	246
				Extra Long	10.5	26.9	8.6	32.8	8.0	35.3	10.7	26.4	9.4	30.1	248
			Automatic	Standard	11.0	25.7	8.8	32.1	8.1	34.9	10.8	26.2	9.6	29.4	252
				Long	11.1	25.5	8.8	32.1	8.2	34.5	10.9	25.9	9.6	29.4	252
				Extra Long	11.3	25.0	9.0	31.4	8.3	34.0	11.0	25.7	9.8	28.8	257
3.160	120 (163)	4x4	Automatic	Standard	13.1	21.6	11.4	24.8	11.6	24.4	16.3	17.3	13.4	21.1	351
				Long	13.1	21.6	11.4	24.8	11.6	24.4	16.3	17.3	13.4	21.1	351
				Extra Long	13.1	21.6	11.4	24.8	11.6	24.4	16.3	17.3	13.4	21.1	351
3.180	130 (177)	4x4	Automatic	Standard	12.3	23.0	9.6	29.4	8.7	32.5	11.1	25.5	10.2	27.7	268
				Long	12.4	22.8	9.8	28.8	8.8	32.1	11.2	25.2	10.3	27.4	271
				Extra Long	12.6	22.4	9.9	28.5	8.9	31.7	11.3	25.0	10.4	27.2	274

All values shown on this page are in accordance WLTP testing regimes. Actual performance will depend on driving style, road conditions, chosen optional extras and other non-technical factors. Values shown are for standard specification only; changes to base specification will alter these values. Contact your MAN Sales Specialist for exact values for your specification. *Vehicle not subject to WLTP testing regime / data not yet available

FUEL CONSUMPTION & EMISSIONS.

Gross Weight [t]	Engine Power [kW (PS)]	Drive Type	Transmission	Length	Consumption (low)		Consumption (medium)		Consumption (high)		Consumption (extra-high)		Consumption (combined)		CO2 (combined) g/km	
					1/100km	MPG	1/100km	MPG	1/100km	MPG	1/100km	MPG	1/100km	MPG		
3.160	120 (163)	Rear	Manual	Standard	10.8	26.2	8.7	32.5	8.4	33.6	11.2	25.2	9.8	28.8	256	
				Long	11.4	24.8	9.3	30.4	8.9	31.7	12.0	23.5	10.4	27.2	273	
				Extra Long	13.1	21.6	11.4	24.8	11.6	24.4	16.3	17.3	13.4	21.1	351	
			Automatic	Standard	*	*	*	*	*	*	*	*	*	*	*	*
				Long	*	*	*	*	*	*	*	*	*	*	*	*
				Extra Long	13.1	21.6	11.4	24.8	11.6	24.4	16.3	17.3	13.4	21.1	351	
5.160	120 (163)	Rear	Manual	Standard	11.8	23.9	9.7	29.1	10.1	28.0	14.9	19.0	11.9	23.7	313	
				Long	11.8	23.9	9.7	29.1	10.1	28.0	14.9	19.0	11.9	23.7	313	
				Extra Long	*	*	*	*	*	*	*	*	*	*	*	
			Automatic	Standard	*	*	*	*	*	*	*	*	*	*	*	*
				Long	*	*	*	*	*	*	*	*	*	*	*	*
				Extra Long	*	*	*	*	*	*	*	*	*	*	*	*
6.160	120 (177)	Rear	Manual	Standard	*	*	*	*	*	*	*	*	*	*		
				Long	*	*	*	*	*	*	*	*	*	*		
				Extra Long	*	*	*	*	*	*	*	*	*	*		
			Automatic	Standard	*	*	*	*	*	*	*	*	*	*	*	
				Long	*	*	*	*	*	*	*	*	*	*	*	
				Extra Long	*	*	*	*	*	*	*	*	*	*	*	

All values shown on this page are in accordance WLTP testing regimes. Actual performance will depend on driving style, road conditions, chosen optional extras and other non-technical factors. Values shown are for standard specification only; changes to base specification will alter these values. Contact your MAN Sales Specialist for exact values for your specification. *Vehicle not subject to WLTP testing regime / data not yet available

FUEL CONSUMPTION & EMISSIONS.

MAN TGE Panel Van with High Roof - LION XP

Gross Weight [t]	Engine Power [kW (PS)]	Drive Type	Transmission	Length	Consumption (low)		Consumption (medium)		Consumption (high)		Consumption (extra-high)		Consumption (combined)		CO2 (combined) g/km
					1/100km	MPG	1/100km	MPG	1/100km	MPG	1/100km	MPG	1/100km	MPG	
3.140	103 (140)	Front	Manual	Standard	9.0	31.4	8.0	35.3	7.6	37.2	10.1	28.0	8.8	32.1	230
				Long	9.2	30.7	8.2	34.5	7.7	36.7	10.2	27.7	8.9	31.7	233
				Extra Long	9.3	30.4	8.3	34.0	7.7	36.7	10.2	27.7	8.9	31.7	234
			Automatic	Standard	10.6	26.7	8.7	32.5	8.1	34.9	10.8	26.2	9.5	29.7	249
				Long	10.7	26.4	8.9	31.7	8.2	34.5	10.9	25.9	9.6	29.4	252
				Extra Long	10.9	25.9	9.0	31.4	8.3	34.0	11.0	25.7	9.7	29.1	255
3.160	120 (163)	Front	Manual	Standard	13.1	21.6	11.4	24.8	11.6	24.4	16.3	17.3	13.4	21.1	351
				Long	13.1	21.6	11.4	24.8	11.6	24.4	16.3	17.3	13.4	21.1	351
				Extra Long	13.1	21.6	11.4	24.8	11.6	24.4	16.3	17.3	13.4	21.1	351
			Automatic	Standard	10.6	26.7	8.7	32.5	8.1	34.9	10.8	26.3	9.5	29.7	249
				Long	13.1	21.6	11.4	24.8	11.6	24.4	16.3	17.3	13.4	21.1	351
				Extra Long	13.1	21.6	11.4	24.8	11.6	24.4	16.3	17.3	13.4	21.1	351
3.180	130 (177)	Front	Manual	Standard	10.3	27.4	8.4	33.6	7.9	35.8	10.6	26.7	9.3	30.4	243
				Long	10.4	27.2	8.6	32.8	8.0	35.3	10.7	26.4	9.4	30.1	246
				Extra Long	10.5	26.9	8.7	32.5	8.0	35.3	10.7	26.4	9.4	30.1	248
			Automatic	Standard	11.1	25.5	8.8	32.1	8.2	34.5	10.9	25.9	9.6	29.4	252
				Long	11.2	25.2	8.9	31.7	8.2	34.5	10.9	25.9	9.7	29.1	255
				Extra Long	11.3	25.0	9.0	31.4	8.3	34.0	11.0	25.7	9.8	28.8	257
3.160	120 (163)	4x4	Automatic	Standard	13.1	21.6	11.4	24.8	11.6	24.4	16.3	17.3	13.4	21.1	351
				Long	13.1	21.6	11.4	24.8	11.6	24.4	16.3	17.3	13.4	21.1	351
				Extra Long	13.1	21.6	11.4	24.8	11.6	24.4	16.3	17.3	13.4	21.1	351
3.180	130 (177)	4x4	Automatic	Standard	12.3	23.0	9.6	29.4	8.7	32.5	11.1	25.5	10.2	27.7	269
				Long	12.4	22.8	9.8	28.8	8.8	32.1	11.2	25.2	10.4	27.2	272
				Extra Long	12.6	22.4	9.9	28.5	8.9	32.7	11.3	25.0	10.6	26.9	275

All values shown on this page are in accordance WLTP testing regimes. Actual performance will depend on driving style, road conditions, chosen optional extras and other non-technical factors. Values shown are for standard specification only; changes to base specification will alter these values. Contact your MAN Sales Specialist for exact values for your specification. *Vehicle not subject to WLTP testing regime / data not yet available

FUEL CONSUMPTION & EMISSIONS.

Gross Weight [t]	Engine Power [kW (PS)]	Drive Type	Transmission	Length	Consumption (low)		Consumption (medium)		Consumption (high)		Consumption (extra-high)		Consumption (combined)		CO2 (combined) g/km		
					1/100km	MPG	1/100km	MPG	1/100km	MPG	1/100km	MPG	1/100km	MPG			
3.160	120 (163)	Rear	Manual	Standard	10.8	26.2	8.7	32.5	8.4	33.6	11.2	25.2	9.8	28.8	256		
				Long	11.4	24.8	9.3	30.4	8.9	31.7	12.0	23.5	10.4	27.2	273		
				Extra Long	*	*	*	*	*	*	*	*	*	*	*	*	
			Automatic	Standard	*	*	*	*	*	*	*	*	*	*	*	*	*
				Long	*	*	*	*	*	*	*	*	*	*	*	*	*
				Extra Long	*	*	*	*	*	*	*	*	*	*	*	*	*
5.160	120 (163)	Rear	Manual	Standard	11.8	23.9	9.7	29.1	10.1	28.0	14.9	19.0	11.9	23.7	313		
				Long	11.8	23.9	9.7	29.1	10.1	28.0	14.9	19.0	11.9	23.7	313		
				Extra Long	*	*	*	*	*	*	*	*	*	*	*	*	
			Automatic	Standard	*	*	*	*	*	*	*	*	*	*	*	*	*
				Long	*	*	*	*	*	*	*	*	*	*	*	*	*
				Extra Long	*	*	*	*	*	*	*	*	*	*	*	*	*
6.160	120 (177)	Rear	Manual	Standard	*	*	*	*	*	*	*	*	*	*	*		
				Long	*	*	*	*	*	*	*	*	*	*	*		
				Extra Long	*	*	*	*	*	*	*	*	*	*	*		
			Automatic	Standard	*	*	*	*	*	*	*	*	*	*	*	*	
				Long	*	*	*	*	*	*	*	*	*	*	*	*	
				Extra Long	*	*	*	*	*	*	*	*	*	*	*	*	

All values shown on this page are in accordance WLTP testing regimes. Actual performance will depend on driving style, road conditions, chosen optional extras and other non-technical factors. Values shown are for standard specification only; changes to base specification will alter these values. Contact your MAN Sales Specialist for exact values for your specification. *Vehicle not subject to WLTP testing regime / data not yet available

DIMENSIONS.

MAN TGE standard panel van with normal roof

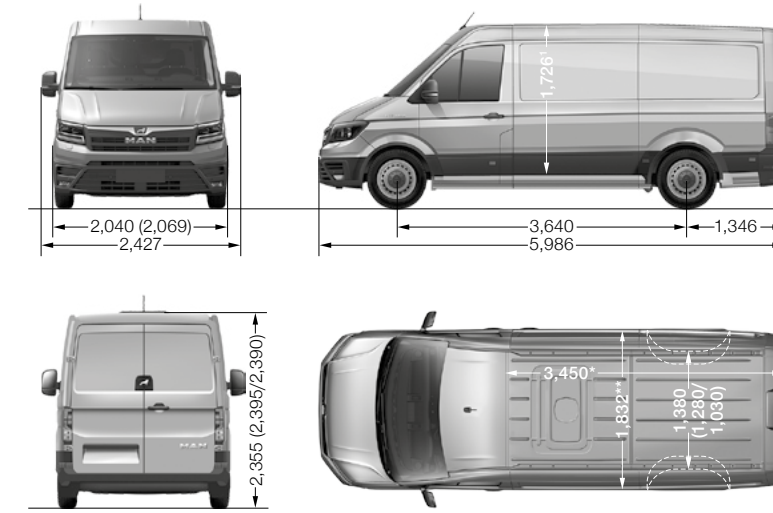

Load compartment, volume [m ³]	9.9 ²
Side sliding door, width x height [mm]	1,311 x 1,587 ³
Rear wing doors, width x height [mm]	1,552 x 1,605 ⁴
Rear loading sill height [mm]	570 ⁵ (720)
Turning circle [m]	13.9 – 14.2

MAN TGE standard panel van with high roof

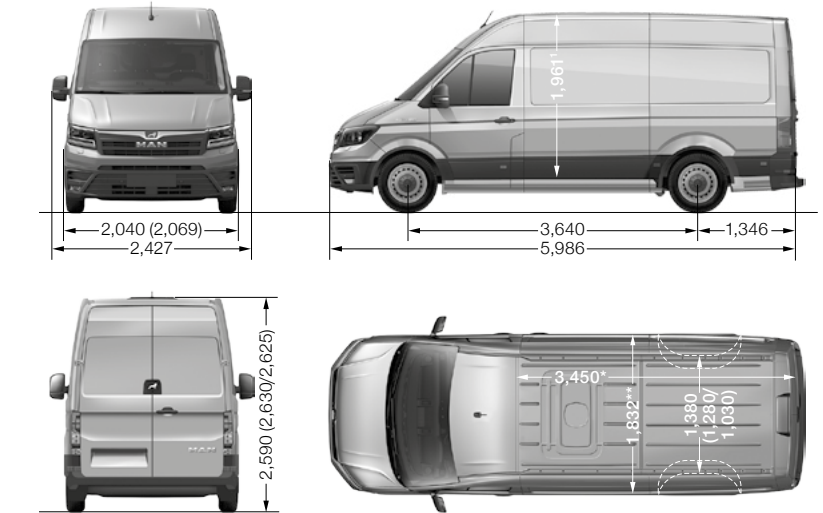

Load compartment, volume [m ³]	11.3 ²
Side sliding door, width x height [mm]	1,311 x 1,822 ³
Rear wing doors, width x height [mm]	1,552 x 1,840 ⁴
Rear loading sill height [mm]	570 ⁵ (720)
Turning circle [m]	13.9 – 14.2

Specifications for 4x4 and rear-wheel drive with normal roof: 1,626/9.3²/1,487³/1,505⁴/670⁵. Specifications for 4x4 and rear-wheel drive with high roof: 1,861¹/10.7²/1,722³/1,740⁴/670⁵. Values in brackets apply for super single-tyre/twin-tyre configuration.

All dimensions determined are using standard vehicles. The height dimensions listed here can vary by approximately ± 40 mm depending on the vehicle equipment. The vehicle drawings are not to scale. ¹Length of the vehicle floor including loading option below the partition. Length in the top area: 3,201 mm. ²Load compartment width at rear axle level, at sliding door level: 1,771 mm.

DIMENSIONS.

MAN TGE long panel van with high roof

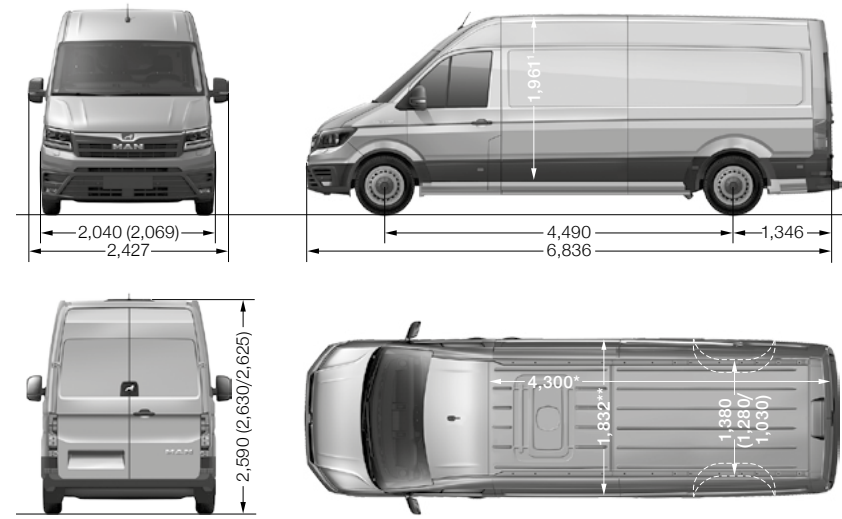

Load compartment, volume [m ³]	14.4 ²
Side sliding door, width x height [mm]	1,311 x 1,822 ³
Rear wing doors, width x height [mm]	1,552 x 1,840 ⁴
Rear loading sill height [mm]	570 ⁵ (720)
Turning circle [m]	16.9

MAN TGE long panel van with super-high roof

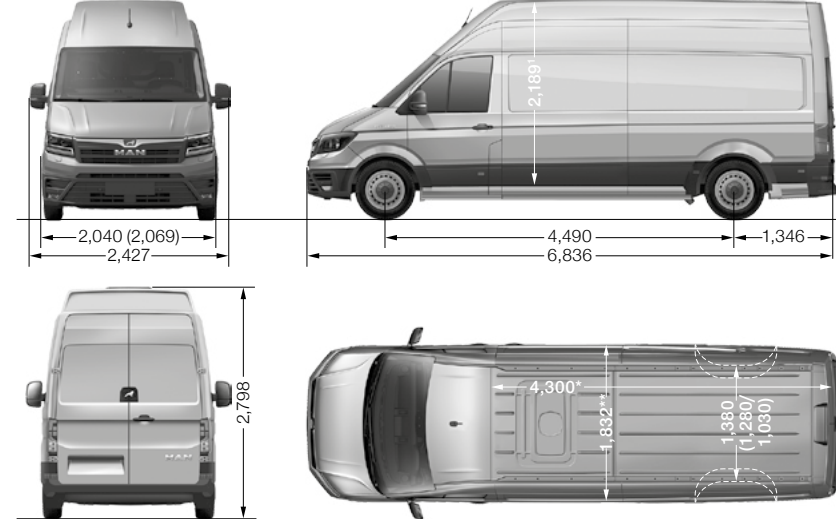

Load compartment, volume [m ³]	16.1 ²
Side sliding door, width x height [mm]	1,311 x 1,822 ³
Rear wing doors, width x height [mm]	1,552 x 1,840 ⁴
Rear loading sill height [mm]	570 ⁵ (720)
Turning circle [m]	16.9

Specifications for 4x4 and rear-wheel drive with high roof: 1,861/13.6²/1,722³/1,740⁴/670⁵.
 Specifications for 4x4 and rear-wheel drive with super-high roof: 2,089¹/15.3²/1,722³/1,740⁴/670⁵.
 Values in brackets apply for super single-tyre/twin-tyre configuration.

All dimensions determined are using standard vehicles. The height dimensions listed here can vary by approximately ± 40 mm depending on the vehicle equipment. The vehicle drawings are not to scale.
¹Length of the vehicle floor including loading option below the partition. Length in the top area: 4,051 mm.
²Load compartment width at rear axle level, at sliding door level: 1,771 mm.

DIMENSIONS.

MAN TGE extra-long panel van with high roof

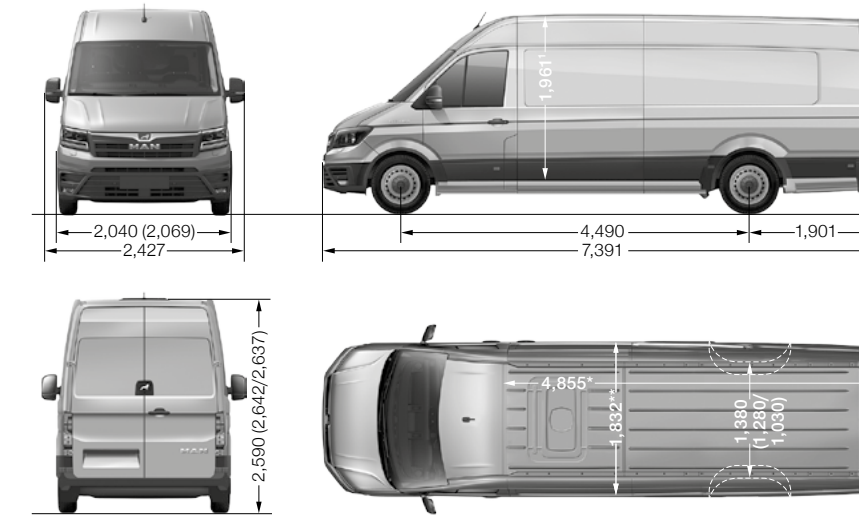

Load compartment, volume [m ³]	16.4 ²
Side sliding door, width x height [mm]	1,311 x 1,822 ³
Rear wing doors, width x height [mm]	1,552 x 1,840 ⁴
Rear loading sill height [mm]	570 ⁵ (725)
Turning circle [m]	16.9

MAN TGE extra-long panel van with super-high roof

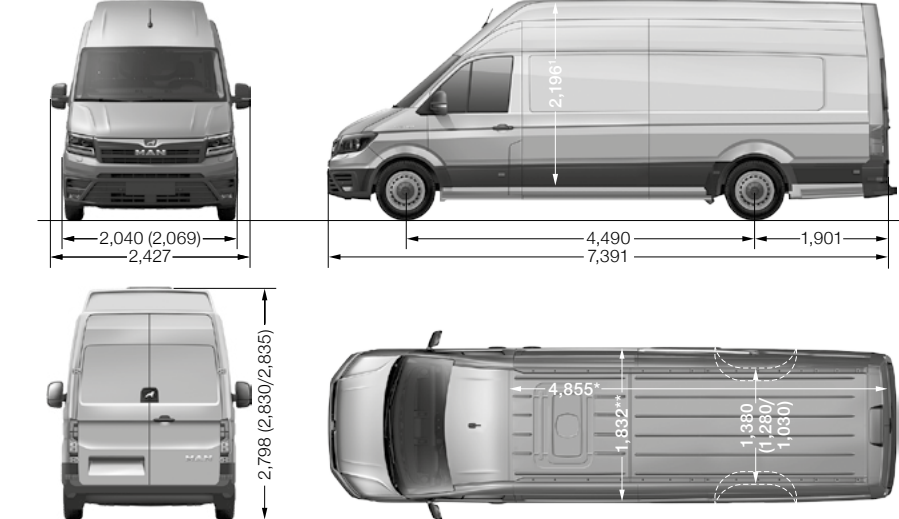

Load compartment, volume [m ³]	18.4 ²
Side sliding door, width x height [mm]	1,311 x 1,822 ³
Rear wing doors, width x height [mm]	1,552 x 1,840 ⁴
Rear loading sill height [mm]	570 ⁵ (725)
Turning circle [m]	16.9

Specifications for 4x4 and rear-wheel drive with high roof: 1,861/15.5²/1,722³/1,740⁴/670⁵.
 Specifications for 4x4 and rear-wheel drive with super-high roof: 2,096¹/17.5²/1,722³/1,740⁴/670⁵.
 Values in brackets apply for super single-tyre/twin-tyre configuration.

All dimensions determined are using standard vehicles. The height dimensions listed here can vary by approximately ± 40 mm depending on the vehicle equipment. The vehicle drawings are not to scale.
¹Length of the vehicle floor including loading option below the partition. Length in the top area: 4,606 mm.
²Load compartment width at rear axle level, at sliding door level: 1,771 mm.

DIMENSIONS.

MAN TGE chassis/cowl chassis cab standard

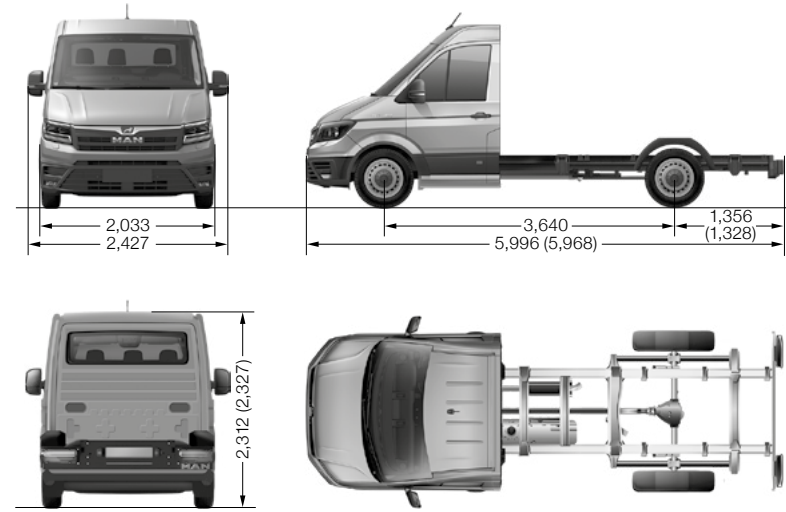

Frame, height [mm] chassis for 3.5/5.0–5.5 kg GVW	760/785
Frame, height [mm] chassis with cowl for 3.5/5.0–5.5 kg GVW	760/785
Frame, height [mm] chassis with flat frame for 3.5 kg GVW	570
Turning circle [m]	13.9 – 14.2
Flatbed length [mm]	3,500

MAN TGE chassis/cowl chassis cab long

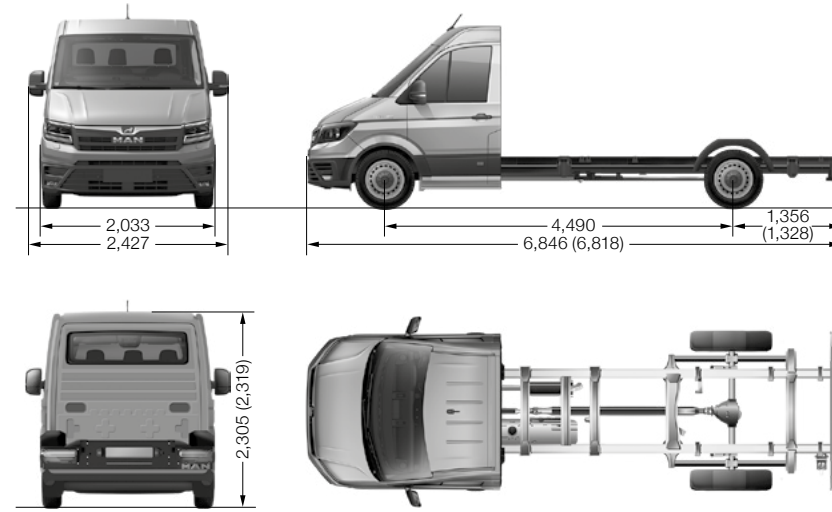

Frame, height [mm] chassis for 3.5/5.0–5.5 kg GVW	760/785
Frame, height [mm] chassis with cowl for 3.5/5.0–5.5 kg GVW	760/785
Frame, height [mm] chassis with flat frame for 3.5 kg GVW	570
Turning circle [m]	16.9
Flatbed length [mm]	4,300

DIMENSIONS.

MAN TGE chassis/cowl chassis cab extra-long

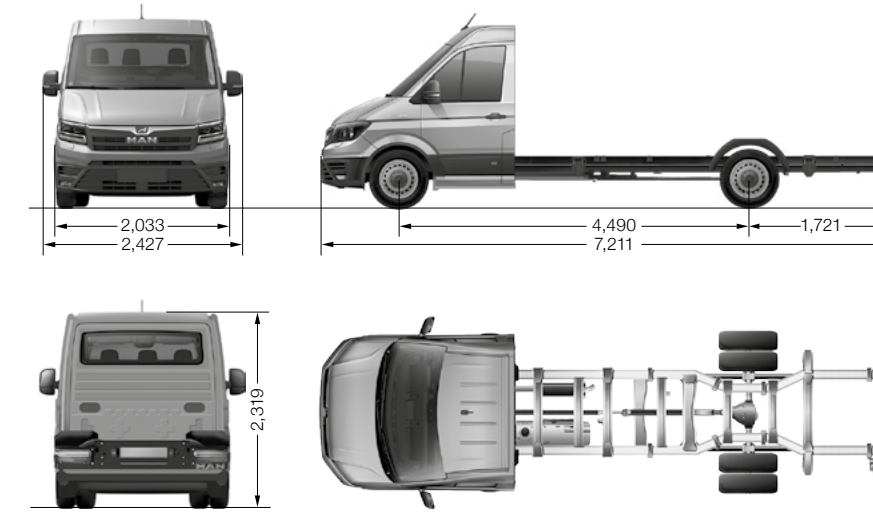

Frame, height [mm] chassis for 3.5/5.0–5.5 kg GVW	760/785
Frame, height [mm] chassis with cowl for 3.5/5.0–5.5 kg GVW	760/785
Turning circle [m]	16.9
Flatbed length [mm]	4,700

Values in brackets apply for twin-tyre configuration.
 Flatbed length valid for trucks with flatbed ex works.
 All dimensions determined are using standard vehicles. The height dimensions listed here can vary by approximately ± 40 mm depending on the vehicle equipment. The vehicle drawings are not to scale.

Flatbed length valid for trucks with flatbed ex works.
 All dimensions determined are using standard vehicles. The height dimensions listed here can vary by approximately ± 40 mm depending on the vehicle equipment. The vehicle drawings are not to scale.

DIMENSIONS.

MAN TGE chassis crew cab standard

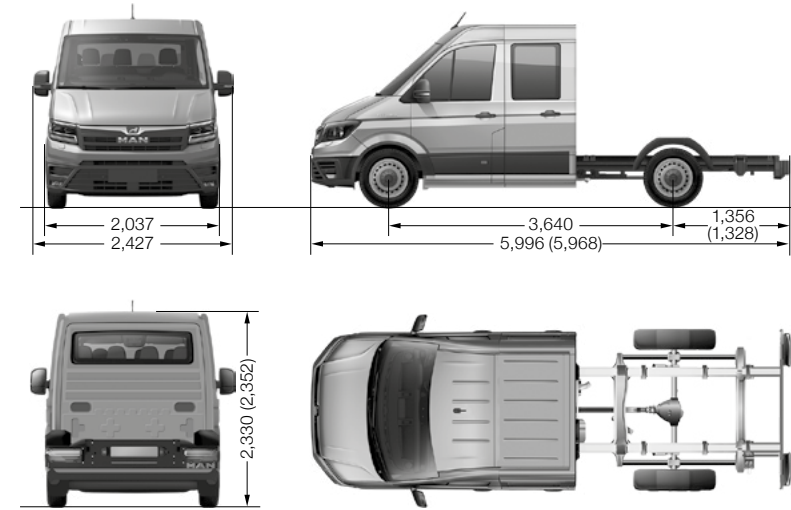

MAN TGE chassis crew cab long

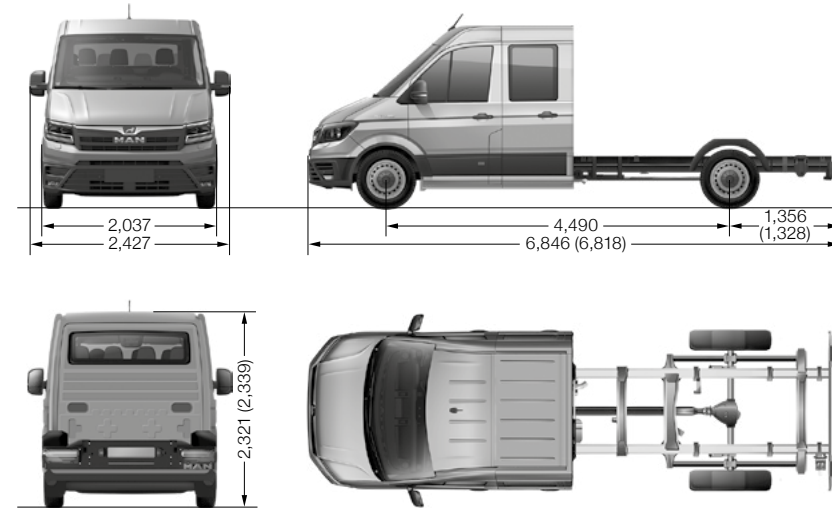

Frame, height [mm] chassis for 3.5/5.0–5.5 kg GVW	760/785	Frame, height [mm] chassis for 3.5/5.0–5.5 kg GVW	760/785
Turning circle [m]	13.9 – 14.2	Turning circle [m]	16.9
Flatbed length [mm]	2,700	Flatbed length [mm]	3,500

Values in brackets apply for twin-tyre configuration.
Flatbed length valid for trucks with flatbed ex works.
All dimensions determined are using standard vehicles. The height dimensions listed here can vary by approximately ± 40 mm depending on the vehicle equipment. The vehicle drawings are not to scale.

WEIGHTS.

MAN TGE Panel Van (LION XS)

Driveline	Permissible gross vehicle weight [kg]	Engine rating [kW (PS)]	Max. trailer load, braked, on 12% gradient/unbraked [kg]	Permissible max. gross train weight [kg]	Permissible axle load, front/rear [kg]	Standard		Long		Extra long	
						Unladen weight [kg]	Payload capacity [kg]	Unladen weight [kg]	Payload capacity [kg]	Unladen weight [kg]	Payload capacity [kg]
Front-wheel drive	3,500	103 (140) LD/HD	3,000/750	6,000	1,800*/2,100	2,274	1,226	2,386	1,114	2,435	1,065
						2,274	1,226	2,383	1,117	2,436	1,064
						2,283	1,217	2,395	1,105	2,445	1,055
All-wheel drive	3,500	120 (163) HD	3,000/750	6,000	1,800*/2,100	2,433	1,057	2,540	960	2,608	892
		130 (177) LD	3,000/750	6,000	1,800*/2,100	2,442	1,058	2,549	951	2,608	892
Rear-wheel drive	3,500	120 (163) HD	3,500/750	7,000	1,800*/2,250	2,355	1,145	2,468	1,032	-	-
Rear-wheel drive	5,000	120 (163) HD	3,500/750	8,000	2,200/3,500	2,584	2,416	2,691	2,309	2,773	2,227
Rear-wheel drive	5,500	120 (163) HD	3,500/750	8,000	2,200/4,000	2,584	2,916	2,691	2,809	2,773	2,727

Roof loads²

Model	Roof load [kg]
Normal roof	300
High roof	150
Super-high roof	0

Drawbar loads

at trailer load [kg]	Drawbar load [kg]	
	Front-wheel drive/All-wheel drive	Rear-wheel drive
2,500	100	-
3,000	120	140
3,500	-	140

*Depending on equipment the permissible front axle load may rise to 2,100 kg. This may affect the minimum payload or the maximum payload capacity.

²Only for Panel van.

All weights on this page include high roof.

For LION XC add 49 kg (standard); 61 kg (long); 68 kg (extra long). For LION XP add 61 kg (standard); 73 kg (long); 80 kg (extra long).

WEIGHTS.

MAN TGE Chassis with Single Cab

Driveline	Permissible gross vehicle weight [kg]	Engine rating [kW (PS)]	Max. trailer load, braked, on 12 % gradient/ unbraked [kg]	Permissible max. gross train weight [kg]	Permissible axle load, front/rear [kg]	Standard		Long		Extra long	
						Unladen weight [kg]	Load capacity† [kg]	Unladen weight [kg]	Load capacity† [kg]	Unladen weight [kg]	Load capacity† [kg]
Front-wheel drive	3,500	103 (140) LD/HD	3,000/750	6,000	1,800*/2,100	1,953	1,547	1,995	1,505	-	-
		120 (163) HD	3,000/750	6,000	1,800*/2,100	1,957	1,543	1,999	1,501	-	-
		130 (177) LD	3,000/750	6,000	1,800*/2,100	1,962	1,538	2,004	1,496	-	-
All-wheel drive	3,500	120 (163) HD	3,000/750	6,000	1,800*/2,100	2,105	1,395	2,148	1,352	-	-
		130 (177) LD	3,000/750	6,000	1,800*/2,100	2,111	1,389	2,154	1,344	-	-
Rear-wheel drive	3,500	120 (163) HD	3,500/750	7,000	1,800*/2,500	2,039	1,461	2,081	1,419	-	-
Rear-wheel drive	5,000	120 (163) HD	3,500/750	8,000	2,200/3,500	2,225	2,775	2,442	2,558	2,285	2,715
Rear-wheel drive	5,500	120 (163) HD	3,500/750	8,000	2,200/4,000	2,225	3,275	2,442	3,058	2,285	3,215

Drawbar loads

at trailer load [kg]	Drawbar load [kg]	
	Front-wheel drive/All-wheel drive	Rear-wheel drive
2,500	100	-
3,000	120	140
3,500	-	140

* Depending on equipment the permissible front axle load may rise to 2,100 kg. This may affect the minimum payload or the maximum payload capacity.
† Load capacity indicates bodywork and payload allowance combined.

WEIGHTS.

MAN TGE Flatframe Chassis Cowl

Driveline	Permissible gross vehicle weight [kg]	Engine rating [kW (PS)]	Max. trailer load, braked, on 12 % gradient/ unbraked [kg]	Permissible max. gross train weight [kg]	Permissible axle load, front/rear [kg]	Standard		Long	
						Unladen weight [kg]	Load capacity† [kg]	Unladen weight [kg]	Load capacity† [kg]
Front-wheel drive	3,500	103 (140) HD	-	-	1,800*/2,100	1,807	1,693	1,824	1,676
		120 (163) HD	-	-	1,800*/2,100	1,816	1,684	1,833	1,667

* Depending on equipment the permissible front axle load may rise to 2,100 kg. This may affect the minimum payload or the maximum payload capacity.
† Load capacity indicates bodywork and payload allowance combined.

WEIGHTS.

MAN TGE Chassis with Crew Cab

Driveline	Permissible gross vehicle weight [kg]	Engine rating [kW (PS)]	Max. trailer load, braked, on 12% gradient/unbraked [kg]	Permissible max. gross train weight [kg]	Permissible axle load, front/rear [kg]	Standard		Long	
						Unladen weight [kg]	Load capacity ² [kg]	Unladen weight [kg]	Load capacity ² [kg]
Front-wheel drive	3,500	103 (140) LD/HD	2,800/750	6,000	1,800*/2,100	2,124	1,376	2,165	1,335
		120 (163) HD	2,000/750	6,000	1,800*/2,100	2,128	1,372	2,168	1,332
		130 (177) LD	3,000/750	6,000	1,800*/2,100	2,134	1,366	2,174	1,326
All-wheel drive	3,500	120 (163) HD	2,800/750	6,000	1,800*/2,100	2,285	1,215	2,322	1,178
		130 (177) LD	2,800/750	6,000	1,800*/2,100	2,290	1,210	2,328	1,172
Rear-wheel drive	3,500	120 (163) HD	3,500/750	7,000	1,800*/2,250	2,210	1,290	2,261	1,239
Rear-wheel drive	5,000	120 (163) HD	3,500/750	8,000	2,200/3,500	2,391	2,609	2,442	2,558
Rear-wheel drive	5,500	120 (163) HD	3,500/750	8,000	2,200/4,000	-	-	2,442	3,058

Drawbar loads

at trailer load [kg]	Drawbar load [kg]	
	Front-wheel drive/All-wheel drive	Rear-wheel drive
2,500	100	-
3,000	120	140
3,500	-	140

* Depending on equipment the permissible front axle load may rise to 2,100 kg. This may affect the minimum payload or the maximum payload capacity.

² Load capacity indicates bodywork and payload allowance combined.

MAN TGE MANUFACTURER OPTION PRICES.

V Code	Description	Panel Van (LION XS)	Panel Van (LION XC)	Panel Van (LION XP)	Single Cab Chassis	Flatframe Cowl	Crew Cab Chassis	RRP [£]
Packages								
639IG	Active safety package	O	O	O	-	-	-	£2,556
639II	Driver assistance systems package for distributor	O	O	O	-	-	-	£1,533
639IJ	Load compartment package for distributor	O	O	O	-	-	-	£1,889
639IL	Tipper package for construction vehicles (single tyres)	-	-	-	O	O	O	£1,420
639IQ	Lights & Vision package	O	O	O	O	O	O	£1,496
639JO	Comfort package	O	O	O	O	O	O	£142
639JP	Comfort package plus	O	O	O	O	O	O	£1,224
639IC	Winter package	O	O	O	O	O	O	£1,759
639MA	MAN Media Van Navigation package	O	O	S	O	O	O	£670
639HP	MAN Media Van Navigation Business package	O	O	O	O	O	O	£840
Cab Interior								
638DC	Gray Mesh-MAN Black / Titanium Black-Palladium / Pearl Gray	O	O	O	O	O	O	£0
638DA	Palladium-Titanium Black / Titanium Black-Palladium / Pearl Gray	O	O	O	O	O	O	£0
634WD	Robust seat trim covers in fabric "Marathon"	O	O	O	O	O	O	£162
634WA	Seat trim covers in leatherette "Mesh"	O	O	O	O	O	O	£66
630FB	Overhead storage compartment on headliner	O	O	O	-	-	-	£182
630FM	Sun visors with mirror	O	O	O	O	O	O	£58
630PR	Smokers' package: 12-V outlet with cigarette lighter, ashtray and 4 beverage holders in the dashboard	O	O	O	O	O	O	£32
Airbags								
634FB	Side and curtain airbags for driver and front passenger	O	O	O	O	-	O	£1,066
630FC	Side and curtain airbag for driver	O	O	O	O	-	O	£942
643FD	Side airbags for driver and front passenger	O	O	O	-	O	-	£649
634FE	Side airbag for driver	O	O	O	-	O	-	£320

O = Optional

- = Not Available

This list details most common options and is subject to change without prior notice.

NB. Some options may not be compatible with others, and some are only available in combination with others. If in doubt, refer to your individual configuration.

MAN TGE MANUFACTURER OPTION PRICES.

V Code	Description	Panel Van (LION XS)	Panel Van (LION XC)	Panel Van (LION XP)	Single Cab Chassis	Flatframe Cowl	Crew Cab Chassis	RRP [£]
Paint								
638EA	Candy White	0	0	0	0	0	0	£0
638EB	Luminous Orange Solid	0	0	0	0	0	0	£0
638EE	Deep Ocean Solid	0	0	0	0	0	0	£0
638EG	Cherry Red Solid	0	0	0	0	0	0	£0
638ED	Indium Gray Metallic	0	0	0	0	0	0	£1,473
638K2	Oyster Silver Metallic	0	0	0	0	0	0	£1,473
638EF	Deep Black Pearlescent	0	0	0	0	0	0	£1,589
Anti-Theft Protection								
631EB	Anti-theft alarm system with backup horn, interior monitoring, and towing protection (for TGE without partition)	0	0	0	-	-	-	£573
631EC	Anti-theft alarm system with backup horn, interior monitoring, and towing protection (for TGE with partition)	-	-	-	0	0	0	£597
Electrical System								
630PE	AGM battery and alternator with increased capacity	0	0	0	0	0	0	£351
630PF	AGM battery and alternator	0	0	0	0	0	0	£131
637FG	Main battery switch	0	0	0	0	0	0	£126
631FG	Second battery with cutoff relay and battery monitoring	0	0	0	0	0	0	£422
630QG	Second battery with high-voltage cut-off relay and monitoring function	0	0	0	0	0	0	£591

O = Optional

- = Not Available

This list details most common options and is subject to change without prior notice.

NB. Some options may not be compatible with others, and some are only available in combination with others. If in doubt, refer to your individual configuration.

MAN TGE MANUFACTURER OPTION PRICES.

V Code	Description	Panel Van (LION XS)	Panel Van (LION XC)	Panel Van (LION XP)	Single Cab Chassis	Flatframe Cowl	Crew Cab Chassis	RRP [£]
Driver Assistance Systems								
632NL	High-beam control Light Assist	0	0	0	0	0	0	£215
630LJ	Acoustic warning when reverse gear is engaged, deactivatable	0	0	0	0	0	0	£307
636JD	Blind spot monitor on both sides, driving-off warning	0	0	S	0	0	0	£650
636JE	Blind spot monitor on the left, driving-off warning	0	0	0	0	0	0	£490
636JF	Blind spot monitor on the right, driving-off warning	0	0	0	0	0	0	£490
636LB	Turning Assist	0	0	0	0	0	0	£206
631ER	Park assist	0	0	0	-	-	-	£850
632KL	Rear view camera system	0	0	S	-	-	-	£262
632KM	Preparation for rear view camera system (inc. camera)	-	-	-	0	0	-	£212
635EE	Lane change system	0	0	S	-	-	-	£360
Seating								
634RE	Comfort seat "Plus" on the right	0	0	0	0	0	0	£325
634RK	Suspended seat ergoComfort in cab in the right	0	0	0	0	0	0	£560
634RJ	Suspended seat ergoActive in cab, front right	0	0	0	0	0	0	£700
634PD	Comfort seat on the left	0	0	0	0	0	0	£230
634PE	Comfort seat "Plus" on the left	0	0	0	0	0	0	£325
634PK	Suspended seat ergoComfort in cab, on the left	0	0	0	0	0	0	£560
634PJ	Suspended seat ergoActive in cab, on the left	0	0	0	0	0	0	£700
634PH	2-seater front passenger bench on the left, with folding table	0	0	S	0	0	0	£460
634YC	Seat heater, left and right, separately controllable	0	0	0	0	0	0	£389

O = Optional

- = Not Available

This list details most common options and is subject to change without prior notice.

NB. Some options may not be compatible with others, and some are only available in combination with others. If in doubt, refer to your individual configuration.

MAN TGE MANUFACTURER OPTION PRICES.

V Code	Description	Panel Van (LION XS)	Panel Van (LION XC)	Panel Van (LION XP)	Single Cab Chassis	Flatframe Cowl	Crew Cab Chassis	RRP [£]
Lighting and Vision								
630GB	Exterior mirrors, power-adjustable and heated	O	S	-	O	O	O	£169
630GC	Exterior mirrors, power-adjustable, heated and folding	O	O	S	O	O	O	£325
632BC	LED headlamps with separate LED daytime running lights	O	O	O	O	O	O	£1,092
633EH	Front fog lamps with cornering light	O	O	O	O	O	O	£272
633HB	Position lamps on the roof, in front	-	-	-	S	O	S	£63
634KB	Rear combination lamps with longer cable (cable length +1.5 m)	-	-	-	O	-	O	£44
637CB	Step illumination	O	O	O	O	O	O	£66
Suspension and Axles								
631BD	Heavy-duty suspension system and shock absorption	O	O	O	O	-	O	£190
631BF	Standard suspension system and shock absorption, heavy-duty stabilisers	O	O	O	O	-	O	£117
631BH	Heavy-duty suspension system and shock absorption, heavy-duty stabilisers	O	O	O	O	-	O	£308
631BI	Standard suspension system/shock absorption and heavy-duty stabilisers (for dual tyres)	O	O	O	O	-	O	£234
631BJ	Heavy-duty suspension system/shock absorption and heavy-duty stabilisers (for dual tyres)	O	O	O	O	-	O	£422
631CL	Differential lock	O	O	O	O	-	O	£663
Radio / Navigation								
639MA	MAN Media Van Navigation package	O	O	S	O	O	O	£670
639MB	MAN Media Van Navigation Business package	O	O	O	O	O	O	£840

O = Optional

- = Not Available

This list details most common options and is subject to change without prior notice.

NB. Some options may not be compatible with others, and some are only available in combination with others. If in doubt, refer to your individual configuration.

MAN TGE MANUFACTURER OPTION PRICES.

V Code	Description	Panel Van (LION XS)	Panel Van (LION XC)	Panel Van (LION XP)	Single Cab Chassis	Flatframe Cowl	Crew Cab Chassis	RRP [£]
Heating / Ventilation								
631ZK	Air conditioning system Climatic in cab	O	S	-	O	O	O	£1,725
631ZM	Air conditioning system Climatronic in cab	O	O	S	O	O	O	£2,288
637NB	Electric air auxiliary heater (1,400 W)	O	O	O	O	O	O	£262
637NL	Heat-insulating laminated windshield, heated	O	O	O	O	O	O	£277
637UB	Water heater with programmable parking heater function and radio remote control	O	O	O	O	O	O	£1,102
637UH	Air heater	O	O	O	O	O	O	£1,480
637UI	Air heater plus auxiliary heater	O	O	O	O	O	O	£2,060
637UJ	Air heater plus auxiliary water heater, programmable	O	O	O	O	O	O	£2,250
637UF	Auxiliary heater	O	O	O	O	O	O	£630
637VB	2nd evaporator (below roof in cab)	O	O	O	O	O	O	£1,036
637VC	2nd heater core (below right seat substructure)	O	O	O	-	O	-	£637
637VD	2nd heater core and 2nd evaporator	O	O	O	O	O	O	£1,649
Instrumentation								
631HF	Digital tachograph (requires additional dashboard components)	O	O	O	O	O	O	£662
631HH	Preparation for Smart Tachograph version 2	O	O	O	O	O	O	£512
Sliding Doors								
635RB	Left sliding door in load compartment, with interlock for certain opening positions	O	O	O	-	-	-	£377
635TC	Right sliding door in load compartment	O	O	O	-	-	-	£685
635TB	Right sliding door in load compartment, with interlock for certain opening positions	O	O	O	-	-	-	£799
635TA	Without right sliding door in load compartment (closed side panel)	O	O	O	-	-	-	£0

O = Optional

- = Not Available

This list details most common options and is subject to change without prior notice.

NB. Some options may not be compatible with others, and some are only available in combination with others. If in doubt, refer to your individual configuration.

MAN TGE MANUFACTURER OPTION PRICES.

V Code	Description	Panel Van (LION XS)	Panel Van (LION XC)	Panel Van (LION XP)	Single Cab Chassis	Flatframe Cowl	Crew Cab Chassis	RRP [£]
Body / Chassis								
631DR	Step in rear, extending over complete width	O	O	O	-	-	-	£144
631DT	Step in rear, extending over half width (when tow coupling is fitted)	O	O	O	-	-	-	£116
635LC	Mud flaps in front and rear	O	O	O	O	-	O	£132
635LD	Mud flap in front	O	O	O	O	O	O	£66
635LB	Mud flap in rear	O	O	O	O	-	O	£66
637FB	Rear under-run protection	-	-	-	O	-	O	£128
637FC	Rear and side under-run protection	-	-	-	O	-	O	£311
637FD	Side under-run protection	-	-	-	O	-	O	£183
Bodybuilder Preparation								
630NS	Wooden floor in the load compartment, with loading edge protection in rear	O	S	S	-	-	-	£377
631JD	Bodybuilder Module	O	O	O	O	O	O	£450
631JE	Bodybuilder Module with telematics preparation	O	O	O	O	O	O	£728
630WS	Tail lift preparation, electrical	O	O	O	-	O	-	£114
631DB	Speed control	O	O	O	O	O	O	£161
631DC	Variable electronic speed governor	O	O	O	O	O	O	£161
631BT	Preparation for roof turn signals	-	-	-	O	O	O	£44
631VC	Preparation for center high-mounted stop lamp	-	-	-	O	O	O	£28
634CM	Preparation for rotating beacons	O	O	O	O	O	O	£46
634KE	Preparation for rear combination lamps with longer cable (cable length +1.5 m)	-	-	-	O	O	O	£44
632DE	Load compartment light preparation	O	O	O	O	O	O	£112

O = Optional

- = Not Available

This list details most common options and is subject to change without prior notice.

NB. Some options may not be compatible with others, and some are only available in combination with others. If in doubt, refer to your individual configuration.

MAN TGE MANUFACTURER OPTION PRICES.

V Code	Description	Panel Van (LION XS)	Panel Van (LION XC)	Panel Van (LION XP)	Single Cab Chassis	Flatframe Cowl	Crew Cab Chassis	RRP [£]
Trailer Hitches								
630DD	Trailer hitch preparation (incl. trailer stabilisation) with wiring harness, outlet, and control unit	O	O	O	O	O	O	£242
630DB	Rigid trailer hitch (incl. trailer stabilisation)	O	O	O	O	-	O	£714
630DC	Removable trailer hitch (incl. trailer stabilisation)	O	O	O	O	-	O	£890
630DE	Trailer hitch preparation (incl. trailer stabilisation) with wiring harness, outlet, control unit and towing bracket	O	O	O	O	-	O	£591
Wheels and Tyres								
630BB	Lockable wheel bolts	O	O	O	O	O	O	£32
633KB	Hub cap with chrome emblem	O	O	S	O	O	O	£24
639KC	Wheel trims (for 16-inch steel wheels)	O	O	O	O	O	O	£88
639HT	Alloy wheels 6.5J x 17	O	O	O	O	O	O	£1,360
639H6	Alloy wheels 6.5J x 17 black	O	O	O	O	O	O	£1,524

O = Optional











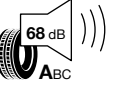

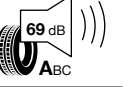

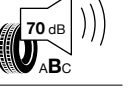

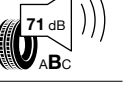
- = Not Available

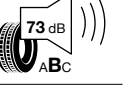
This list details most common options and is subject to change without prior notice.

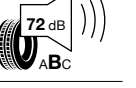
NB. Some options may not be compatible with others, and some are only available in combination with others. If in doubt, refer to your individual configuration.



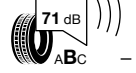
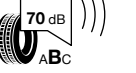





TYRE LABEL.

MAN TGE

Summer tyres	Size	Tyre class	Fuel efficiency	Wet grip	External roll noise	Snow grip	Ice grip
	205/75 R 16 C 113/111	C2	A-C	A-B	 - 	-	-
	235/65 R 16 C 115/113	C2	A-C	A-C	 - 	-	-
	235/65 R 16 C 121/119	C2	A-C	A-B	 - 	-	-
	205/70 R 17 C 115/113	C2	C	A-B	 - 	-	-
	235/60 R 17 C 117/115	C2	A-B	A		-	-
All-year tyres	Size	Tyre class	Fuel efficiency	Wet grip	External roll noise	Snow grip	Ice grip
	205/75 R 16 C 113/111	C2	B-C	B	 - 		-
	235/65 R 16 C 115/113	C2	B-C	A-B	 - 		-
	235/65 R 16 C 121/119	C2	B	A			-
	285/55 R16 C 126/124	C3	D-E	A	 - 		-

TYRE LABEL.

MAN TGE

Winter tyres	Size	Tyre class	Fuel efficiency	Wet grip	External roll noise	Snow grip	Ice grip
	205/75 R 16 C 113/111	C2	D	B			-
	235/65 R 16 C 115/113	C2	C-D	B	 - 		-
	235/65 R 16 C 121/119	C2	C	B			-
	205/70 R 17 C 115/113	C2	C	B			-



Roll resistance / fuel efficiency – The fuel efficiency class of the tyres varies depending on the roll resistance between
 – A for the most efficient tyres that save fuel and
 – E for the least efficient tyres that consume the most fuel.



Wet grip – The wet grip class provides information about the braking properties in wet weather conditions and ranges from A (greatest safety) to E (least safety).



External noise emission – A quieter tyre increases your driving comfort and reduces the impact on the environment by creating less noise. The rolling noise of the tyres is measured in decibels (dB) and is divided into three levels.



Snow grip – Tyres marked with this symbol are suitable for use in extremely snowy conditions. Only tyres with this symbol on the tyre label or the tyre wall are permissible winter tyres.



Ice grip – Tyres marked with this symbol are designed for road surfaces with a layer of ice or a solid snow cover. This specification only exists if the tyres can show these properties.

You can obtain more information on the tyre labels with the configuration of the vehicle and in the offer. Your MAN Service Partner would be happy to provide you with detailed information if you have any questions. More information concerning the tyre labels can be found on the commission website: [Tyres | EU Commission \(europa.eu\)](https://tyres.europa.eu)
 The actual fuel consumption and road safety depends to a great extent on your own driving style: – Fuel consumption can be significantly reduced by driving in an environmentally-friendly manner. – The tyre pressure must be checked at regular intervals to improve fuel efficiency and wet grip. – The stopping distances must always be observed. – Ice tyres are designed for road surfaces with a layer of ice or solid snow cover and should only be used for very severe weather conditions (e.g. low temperatures). The use of ice tyres for less severe weather conditions (e.g. wet or warmer temperatures) may lead to sub-optimum performance, in particular with regard to wet grip, handling and wear.

Ordering a specific tyre brand is not possible for logistical and production reasons.

NOTES

The publication covers the TGE NEXT LEVEL United Kingdom Specification (Model Year 2025).

Unladen vehicle weights listed here include 75 kg for the driver and all operating fluids and fuel tank at 90% full, and are subject to manufacturing tolerance of +/- 2.5%. The unladen weights are calculated using standard UK specification, and in case of panel vans show high roof. Equipment or equipment lines may affect the unladen weight. Contact your MAN dealer for a specific vehicle weight based on your exact configuration required. A vehicle's actual payload, which results from calculating the difference between the gross vehicle weight and the unladen weight can only be determined by weighing the individual vehicle.

Engines are fitted with a multi-step exhaust gas after-treatment system (diesel particulate system and SCR catalytic converter). The SCR catalytic converter (Selective Catalytic Reduction) selectively converts nitrogen oxide (NO_x) exhaust components into diatomic nitrogen (N₂) and water (H₂O). The conversion is carried out with the help of a synthetically-produced, water-based urea solution such as AdBlue® (ISO 22241-1/AUS 32), which is stored in an auxiliary tank. Depending on the vehicle, the customer must also refill the AdBlue® independently or have it refilled at the MAN Service-Partner between service intervals.

Please note that some optional extras are bound to specific combinations and/or cannot be combined and may be subject to certain legal requirements. MAN will explicitly not be held liable for the improper use of such optional equipment. Certain optional extras may lead to longer delivery periods.

The vehicles illustrated in this document may include optional equipment at extra charge.

We reserve the right to alter specification and price without prior notice.

MAN Truck & Bus UK Ltd.,
Frankland Road, Blagrove,
Swindon, Wiltshire SN5 8YU
www.mantruckandbus.co.uk

Ref: MAN TGE Van Technical Price and Data /14
Issue Date: January 2025
Subject to modifications in the course of progress.